

Reg No.: _____



Jyothi Engineering College(Autonomous)

B. Tech Degree S1 (R) Examination, December 2025 (2025 Scheme)

25EST106- ENGINEERING MECHANICS

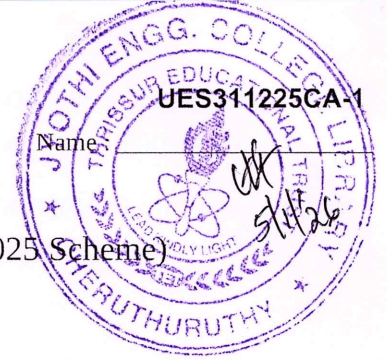

Total Mark: 60

Total Time: 2hrs 30 min

CO MARK

PART A

(Answer All Questions. Each question carries 3 marks)

1. Draw Free body Diagram for the figure given below.

CO1 (3)

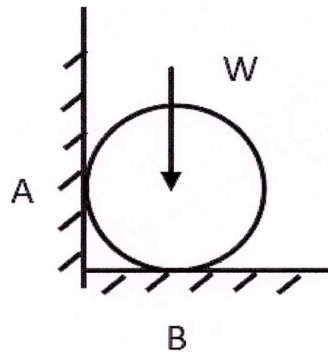

2. A traffic signal of mass 500 N is hung with the help of two strings, as shown in figure. Find the forces induced in the strings using Lami's theorem.

CO1 (3)

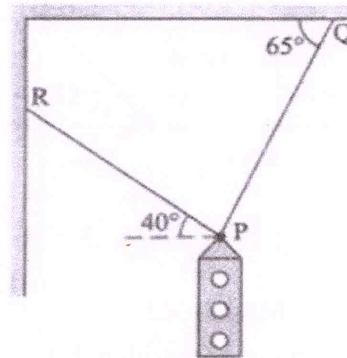

3. A block shown in figure is just moved by a force of 200 N. The weight of the block is 600 N. Determine the coefficient of static friction between the block and the floor.

CO2 (3)

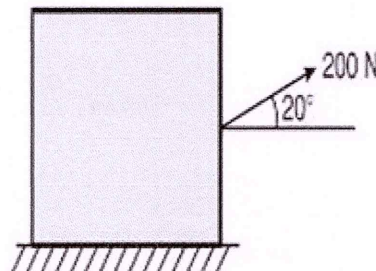

4. State and prove the perpendicular axis theorem.
5. A body is moving with a velocity of 20 m/s. After 10 seconds, the body's velocity reaches 50 m/s. Find the acceleration of the body and the distance travelled while accelerating.
6. State and explain D' Alembert's principle.

CO3 (3)

CO4 (3)

CO4 (3)

7. A wheel rotating about a fixed axis at 20 rpm is uniformly accelerated for 70 seconds, during which it makes 50 revolutions. Find the angular velocity at the end of this interval. CO5 (3)
8. A projectile is projected at an angle of 60° with the horizontal. The horizontal range of the particle is 3 km. Find velocity of projection. CO5 (3)

PART B

(Answer any one full question from each module, each question carries 9 marks)

Module - 1

9. Four forces are acting on a bolt as shown in figure. Determine the magnitude and direction of the resultant force. CO1 (9)

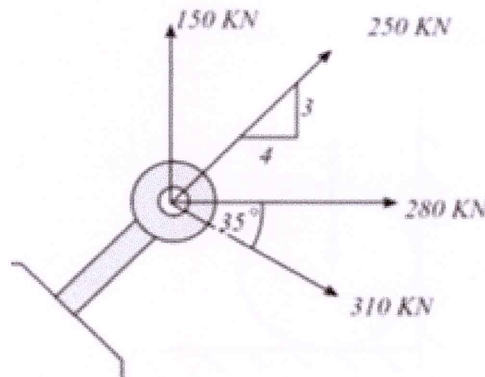

OR

10. A beam is hinged at A and roller supported at B. It is acted upon by loads as shown below. Find the reactions at A & B. CO1 (9)

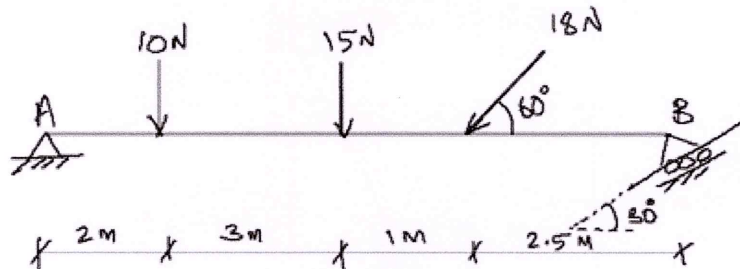

Module - 2

11. Determine the centroid of the Z section, where the width at all sections is 20 mm. CO3 (9)

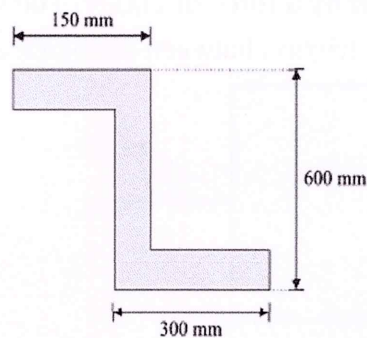

OR

12. A block A weighing 15 N is a rectangular block resting on a rough inclined plane as the shown in figure. The block is tied up by a string which has a tension of 7 N. Find
- The frictional force on the block.
 - The normal reaction of the inclined plane.
 - The coefficient of friction between the surfaces in contact.

CO2 (9)

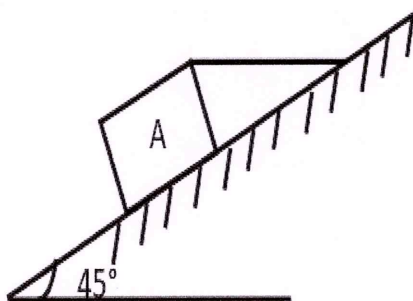

Module - 3

13. The equation of motion of a particle along a straight line is given by $S = 18t + 3t^2 - 2t^3$, where s is the distance travelled from the starting point in meters at the end of t seconds. Find

CO4 (9)

- The velocity and acceleration at the starting.
- The time when the particle reaches maximum velocity.
- The maximum velocity of the particle.

OR

14. Two blocks are joined by an inextensible string as shown in figure. The block resting in the horizontal surface is placed 10m away from the edge. If the system is released from rest, determine the velocity of block after it has moved 4 m. Also, find the time at which the horizontal block reaches the edge of the surface. Assume the coefficient of friction between the block and the plane is 0.2. The pulley is weightless and frictionless.

CO4 (9)

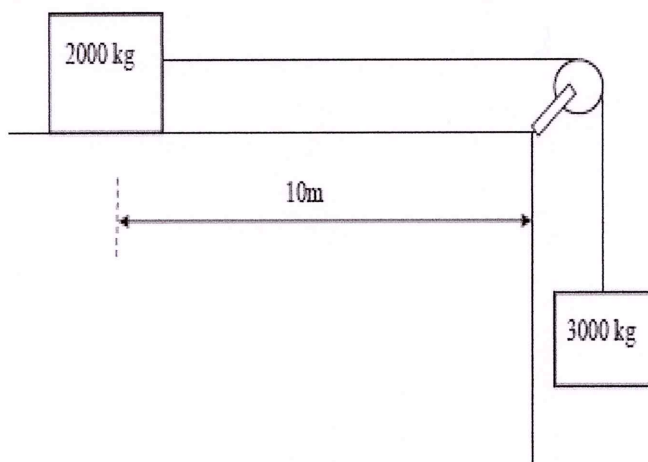

Module - 4

15. A circular disc of radius $r=30$ cm and weight $W=145$ N is free to rotate about its geometric axis. A flexible cord carrying a weight of $Q= 45$ N, is wound around the circumference of the disc as shown in figure. If the weight Q is released from rest, find (a) the time t required for it to fall through the height $h=300$ cm (b) with what velocity ' v ' will it strike the floor?

CO5 (9)

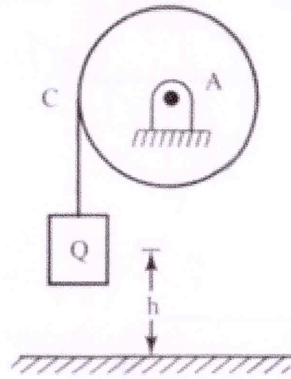

OR

16. A flywheel rotates with a constant retardation due to braking. In the first 10 seconds, it made 300 revolutions. At time $t = 7.5$ sec, its angular velocity was 40π rad/sec. Determine (i) the value of constant retardation, (ii) the total time taken to come to rest, and (iii) the total revolutions made till it comes to rest.

CO5 (9)
